

SPECIFICATIONS	
WEIGHT	545 LBS (247.2 KG)
ELECTRICAL	UNIVERSAL INPUT 100V - 240V VAC 50/60 Hz POWER CONSUMPTION 1800 WATTS MAX
AIR FEED	5 SCFM @ 80 PSI (141 LPM @ 5.5 BAR)
PASS THROUGH	UP TO 11 IN (280 MM)
BAG SIZES	W 10-22 IN (254 - 559 MM) L 10-36 IN (254 - 914 MM)
WEIGHT CAPACITY	UP TO 10 LBS (4.5 KG)

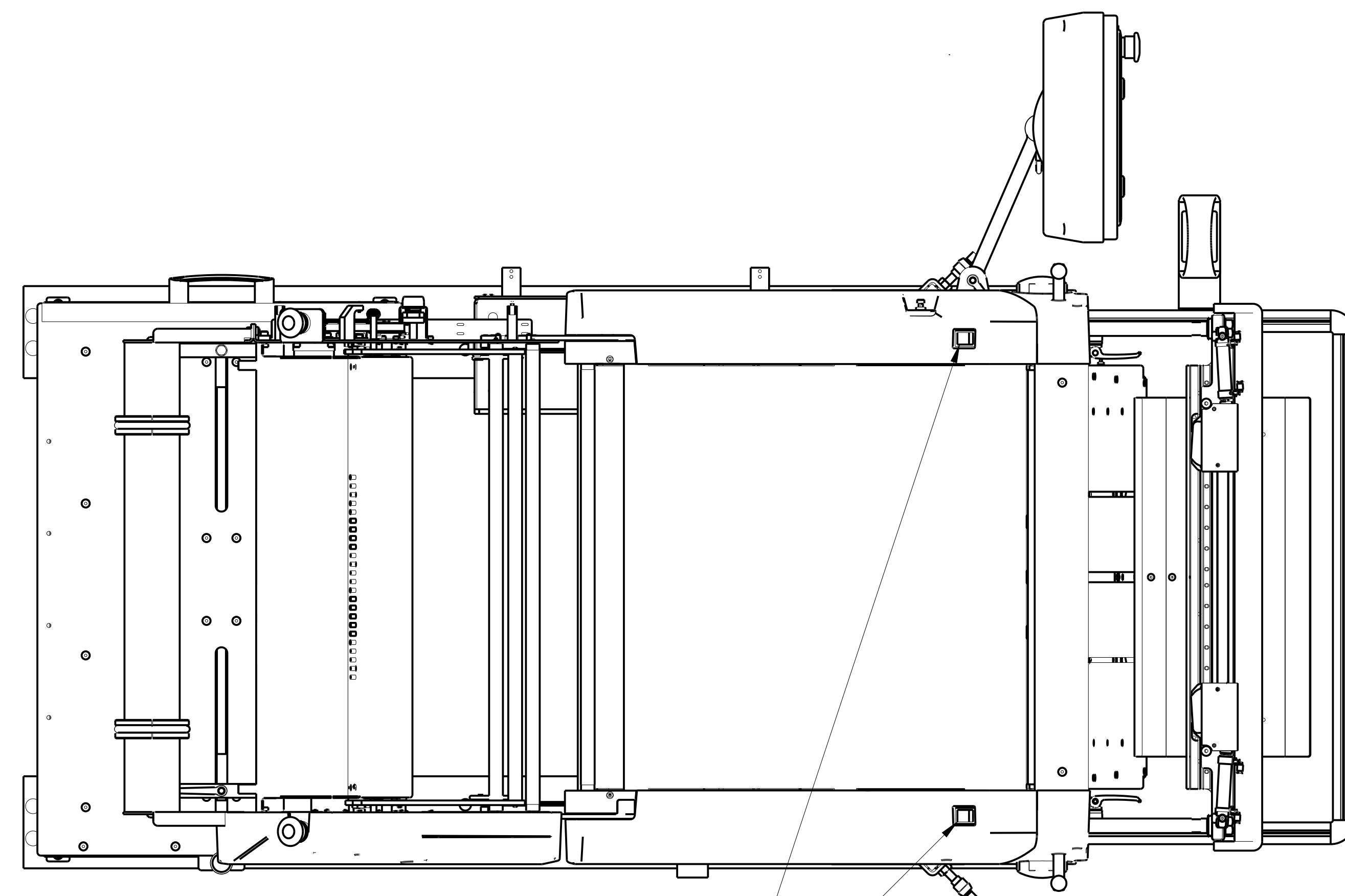

JOG BUTTON

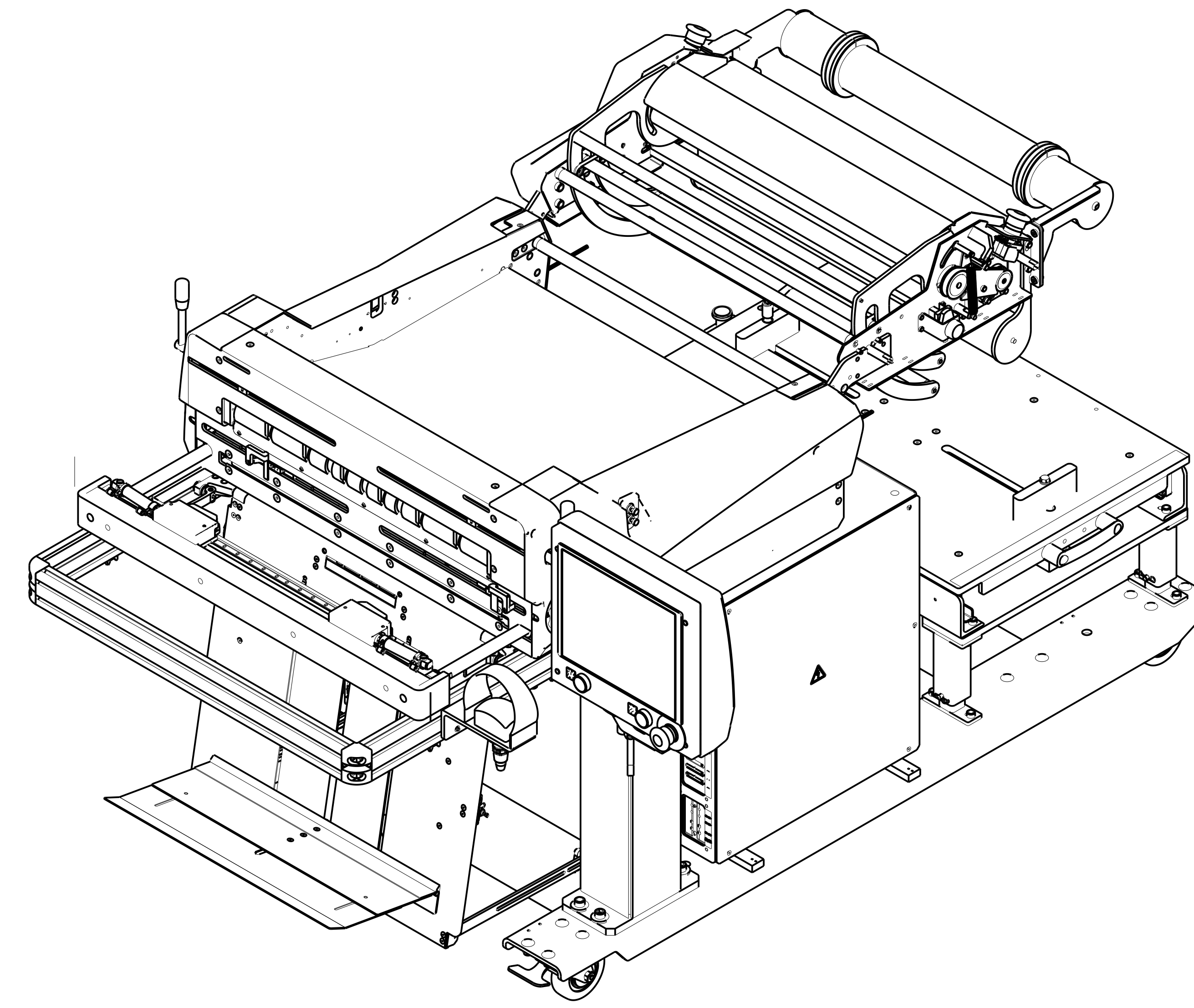

SCALE 3/16

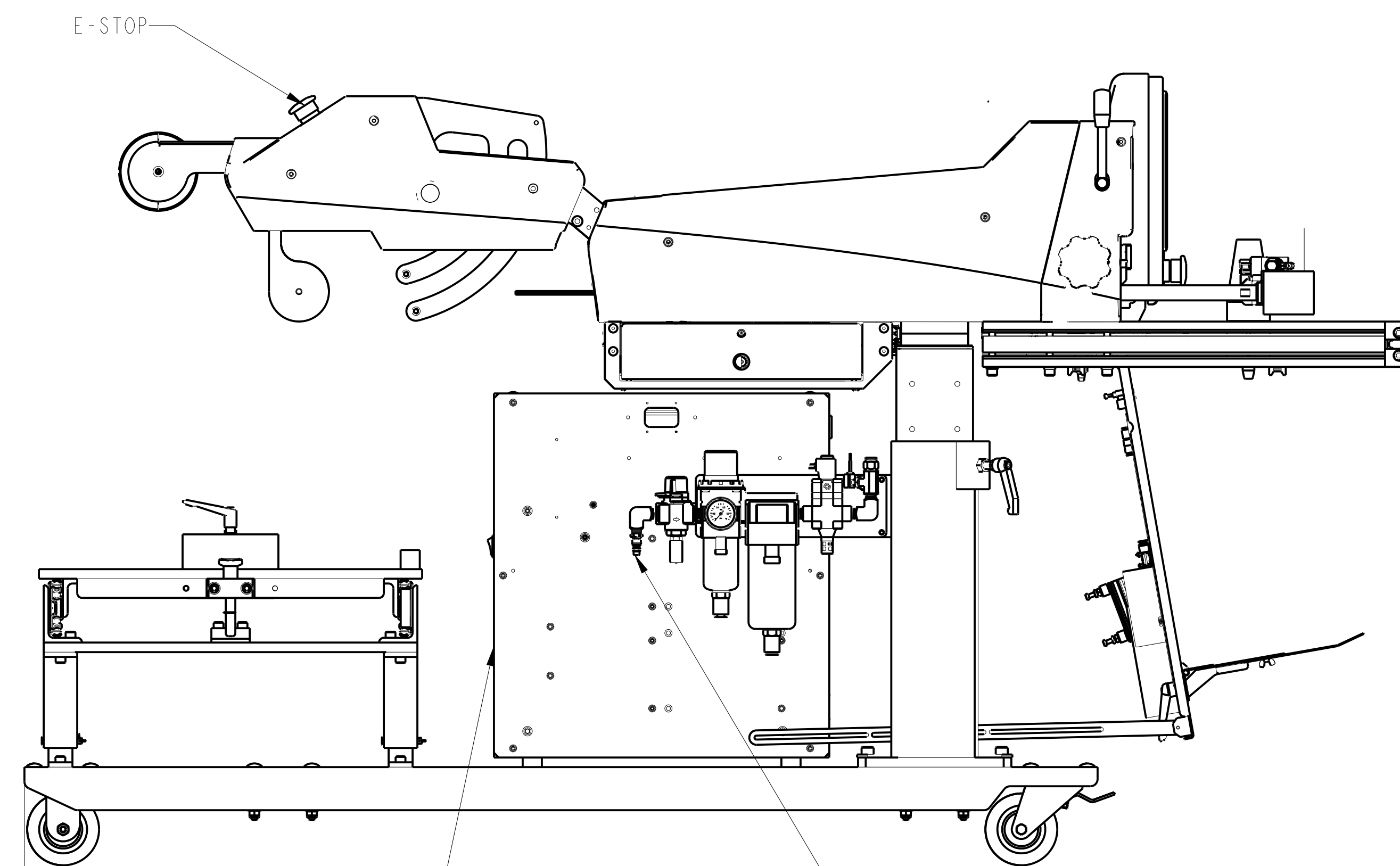

E-STOP

ELECTICAL CONNECTION

PNEUMATIC CONNECTION

72.3  
(1839 mm)

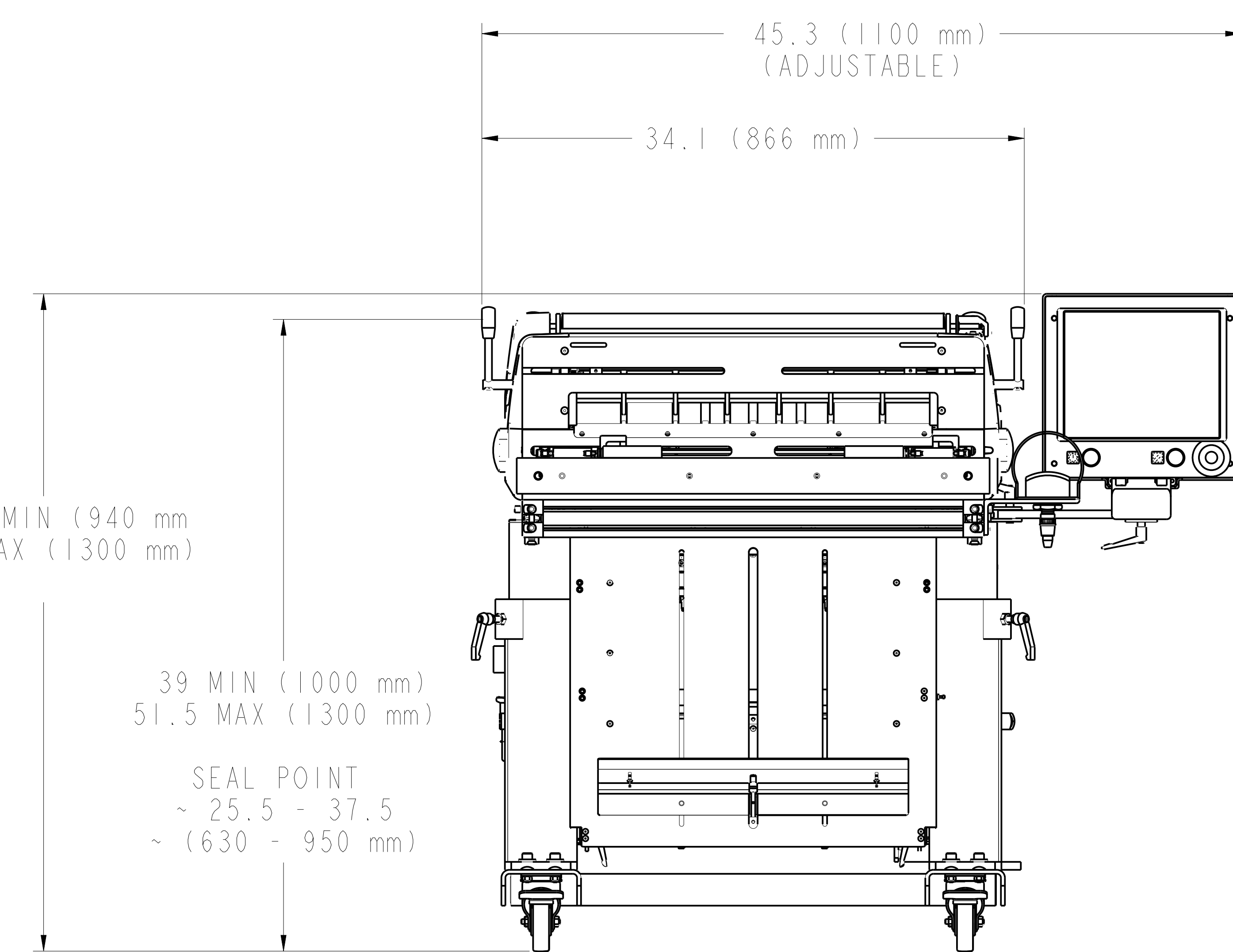

45.3 (1100 mm)  
(ADJUSTABLE)

34.1 (866 mm)

36.8 MIN (940 mm)  
49.3 MAX (1300 mm)

39 MIN (1000 mm)  
51.5 MAX (1300 mm)

SEAL POINT  
~ 25.5 - 37.5  
~ (630 - 950 mm)

REV	BY	DATE	ECN	DESCRIPTION
B	GHW	6-11-20		ADDED METRIC DIMENSIONS
A	GHW	7-17-17	1131	RELEASED

FINISH	NONE
MATERIAL	N/A
MACHINING SURFACES TO BE NO GREATER THAN 125 (3.2) ✓ GREEN COATED SURFACES PARTS MUST BE FREE OF BURRS AND SHARP EDGES	
TOLERANCES	FRACTIONS
1 PLACE DIMS	± .1
2 PLACE DIMS	± .05
3 PLACE DIMS	± .01
ANGLES	± .1°

DRAWING SIZE	E	SCALE	3/32	DRAWN BY	GHW	DATE	7-17-17
TITLE	FOOTPRINT		AB800	DRAWING NO.	FP236	SHEET 1 OF 1	REV.

Automated PACKAGING SYSTEMS	
10175 PHILIPP PARKWAY - STREETSBORO, OH 44221	