

SPECIFICATIONS	
WEIGHT	450 LBS (204.1 KG)
ELECTRICAL	UNIVERSAL INPUT, 100V TO 240V VAC, 50/60 Hz POWER CONSUMPTION: 1800W (VA) MAX
AIR FEED	5 CFM/80 PSI OF CLEAN, DRY AIR
PASS-THROUGH	UP TO 6 INCHES (152 MM)
BAG THICKNESS	1.09 - 4.0 MIL
BAG SIZES	WIDTH: 4 to 16 INCHES (102 TO 406 MM) / LENGTH: 5.5 to 27 INCHES (140 TO 686 MM)
WEIGHT CAPACITY	UP TO 5 LBS (WITH LOAD SHELF)

PRINTER SPECIFICATIONS	
WEIGHT	68 LBS (31 KG)
ELECTRICAL	100-240V, 50/60 Hz, 2.4 KW
AIR FEED	SUPPLIED FROM BAGGER
LABEL SIZE	UP TO 4 INCHES (102 MM) WIDE, 20 INCHES (508 MM) LONG

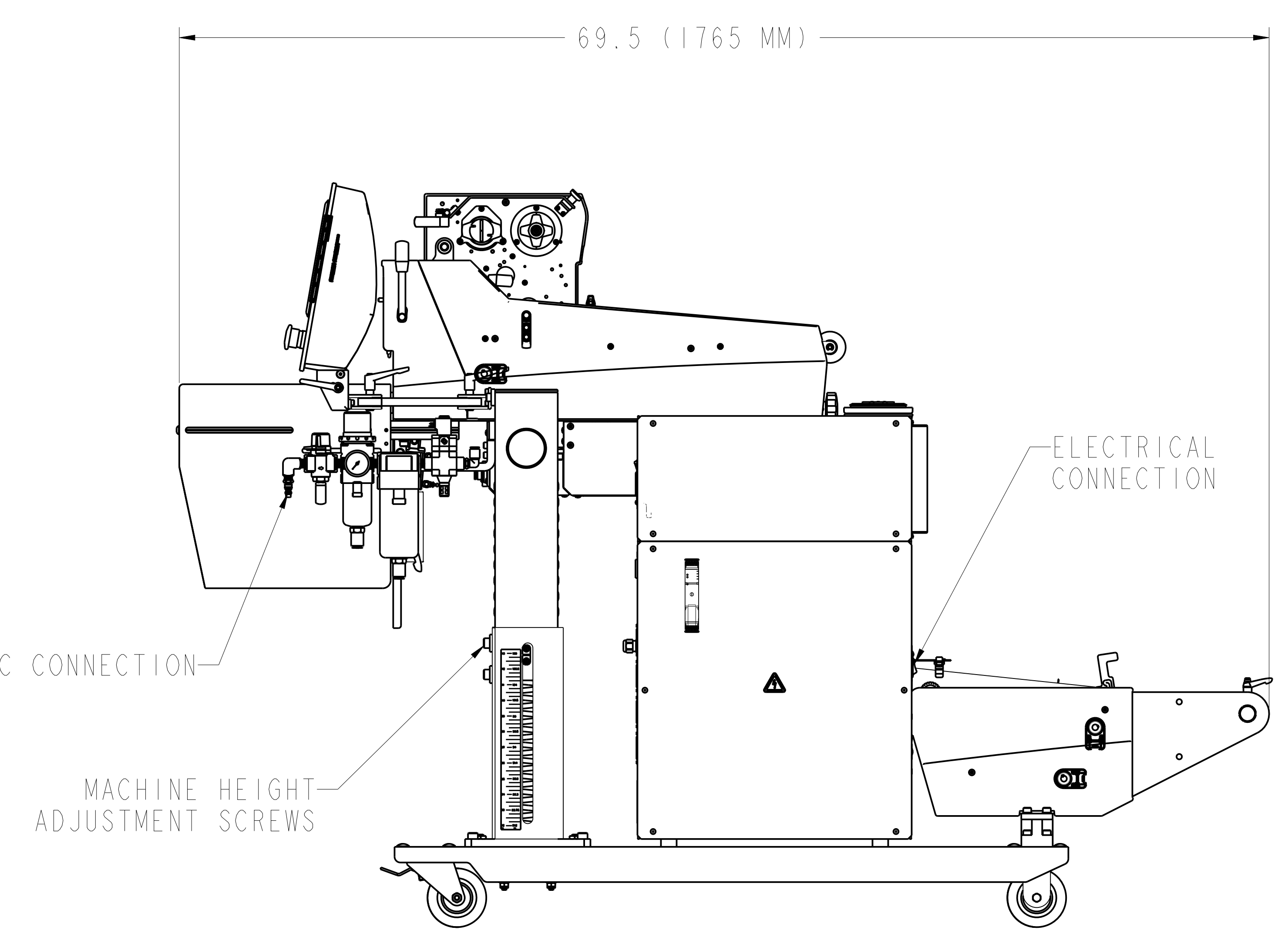
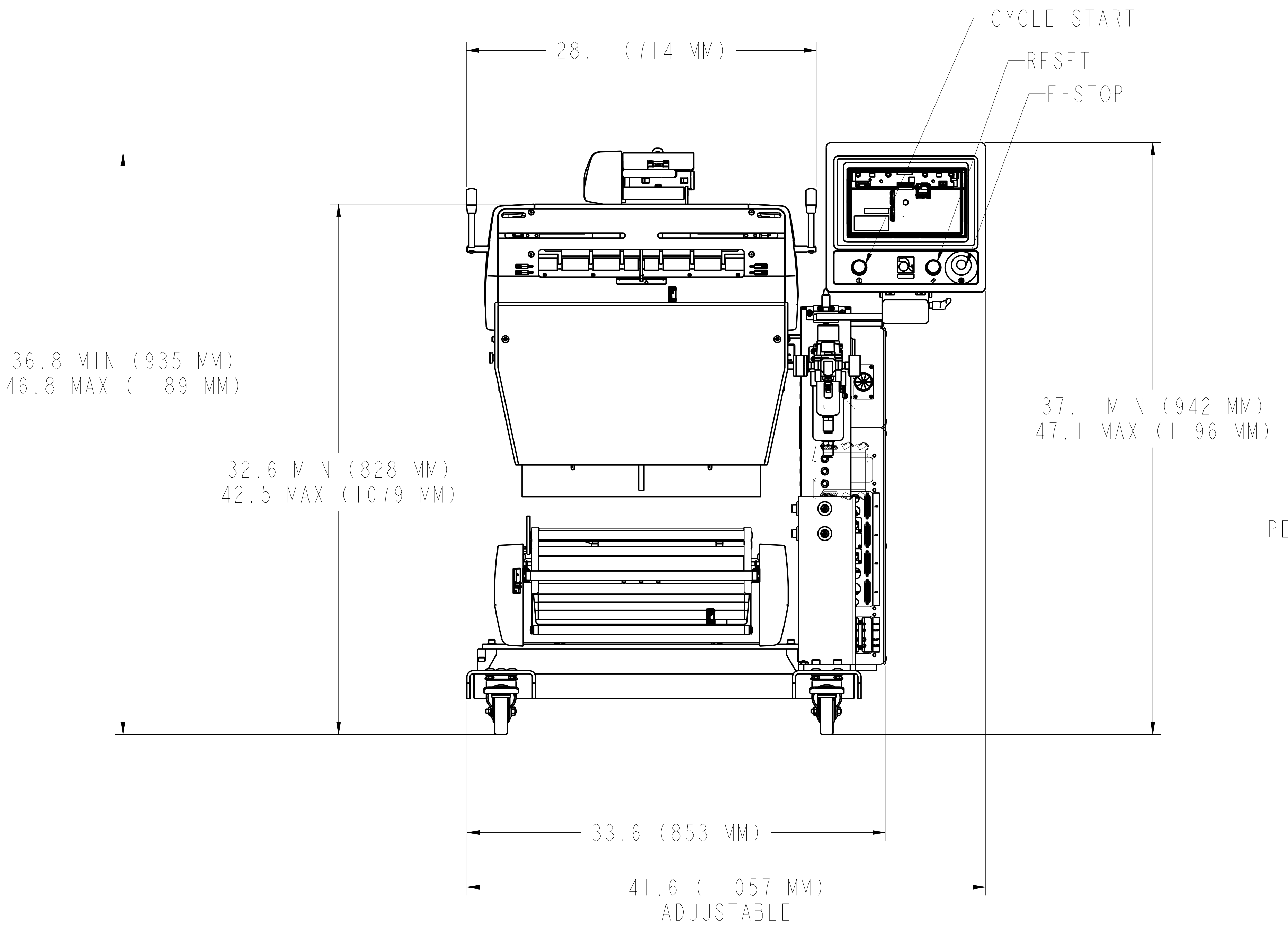
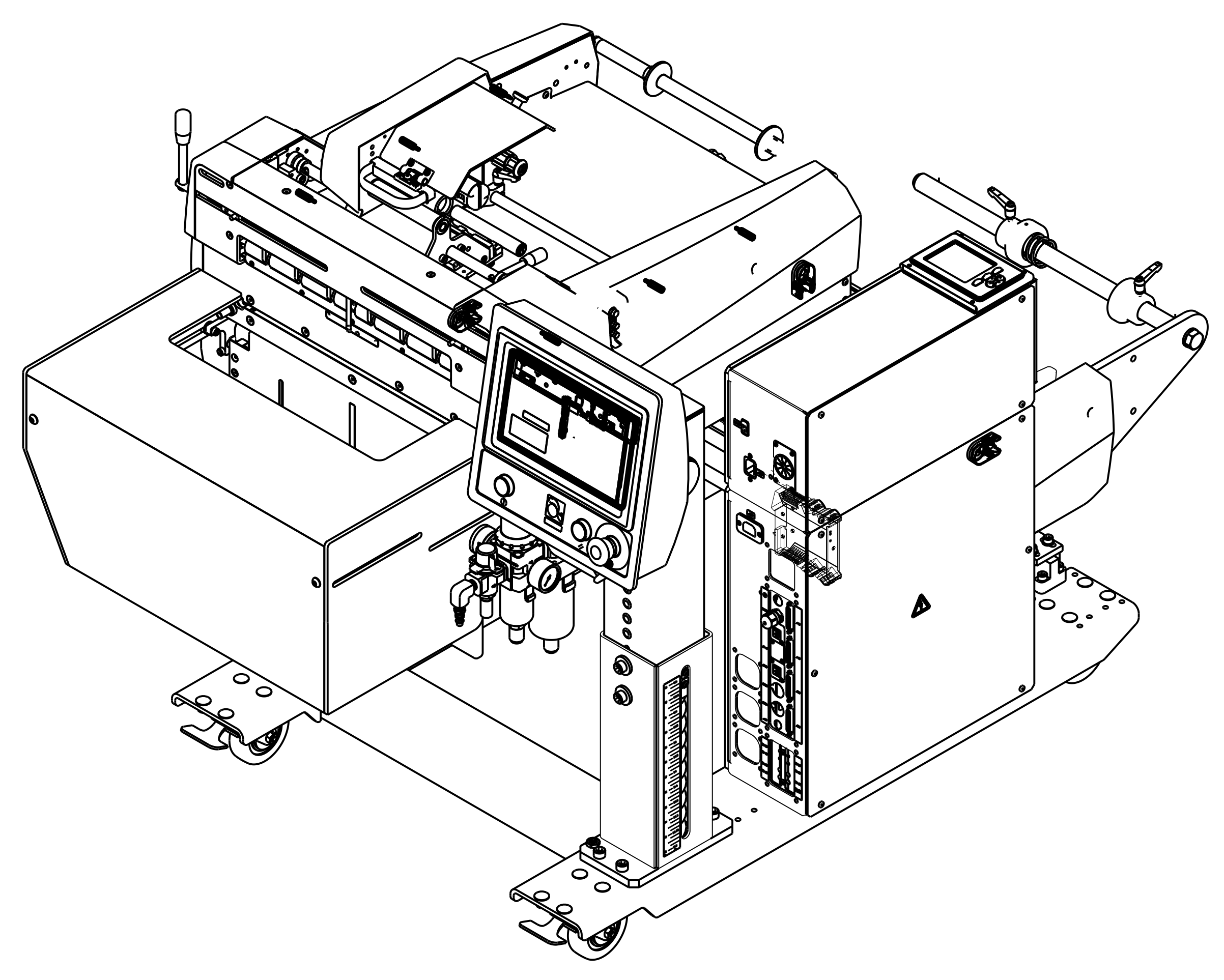
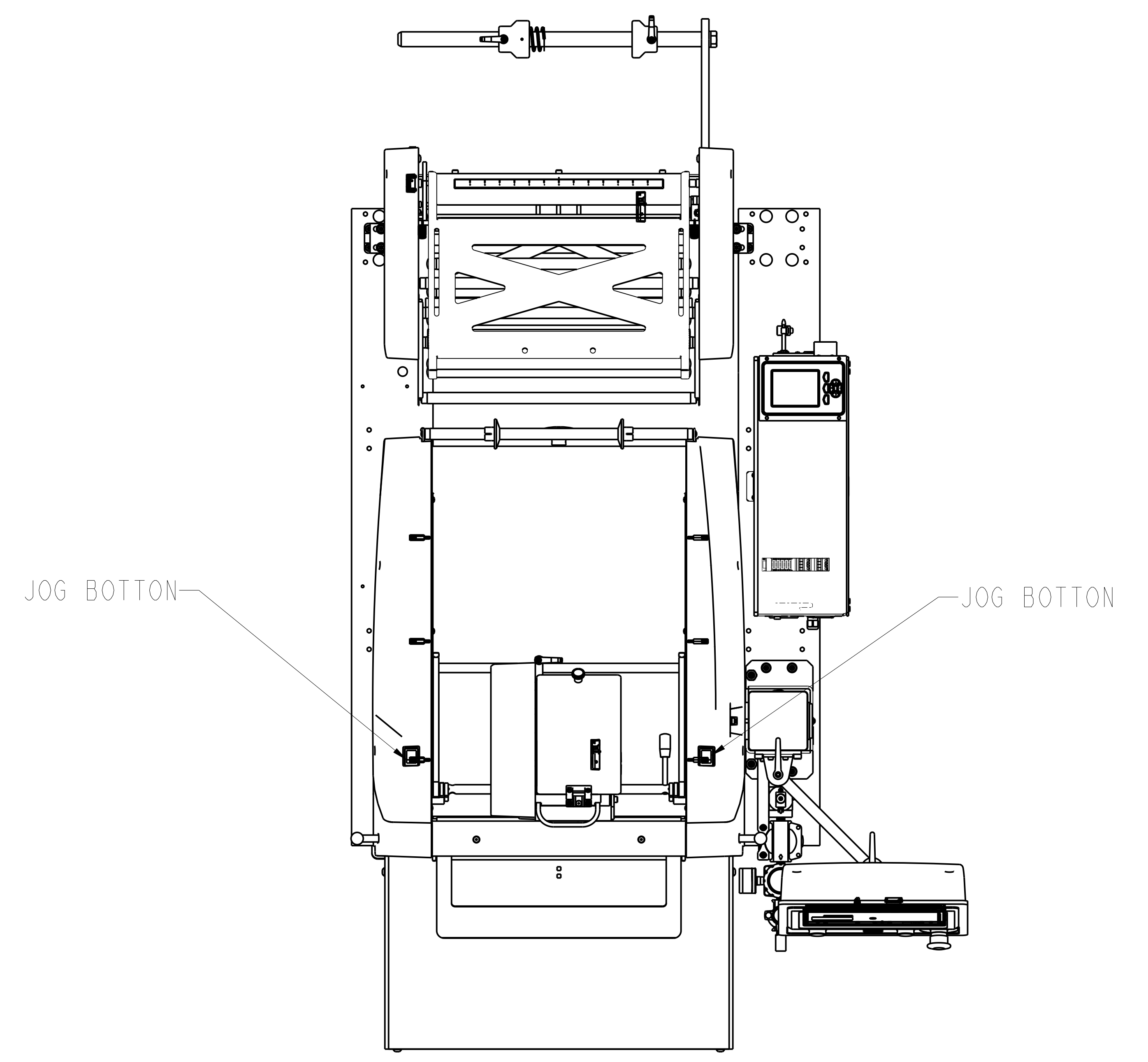

Fabricated & Documented to be RoHS Compliant

REV	BY	DATE	ECN	DESCRIPTION
B	AZ	1-23-20		METRIC DIMENSIONS
A	DMF	4-1-19	1896	RELEASED

FINISH	NONE
MATERIAL	N/A
MACHINING SURFACES TO BE NO GREATER THAN 125 (3.2) ✓ FREEZE SURFACE NOTES PART MUST BE FREE OF BURRS AND SHARP EDGES	
TOLERANCES UNLESS OTHERWISE SPECIFIED	
1 PLACE DIMS	± .12
2 PLACE DIMS	± .01
3 PLACE DIMS	± .005
ANGLES	± .1°

DRIVING SIZE	SCALE	DRAWN BY	DATE	REV	DATE	DESCRIPTION
E	1/4	DMF	4-1-19	1	1-23-20	RELEASED

Automated PACKAGING SYSTEMS
10175 PHILIPP PARKWAY - STREETSBORO, OH 44221

FOOTPRINT, AB650

AB650